



# A RELIABLE FRONT LOADER

A FRONT LOADER RANGE THAT BUILDS ON THE TRADITIONAL TRIMA VALUES.

Q-series

- |                 |                 |
|-----------------|-----------------|
| Q3 <sup>S</sup> | Q5 <sup>M</sup> |
| Q3 <sup>M</sup> | Q5 <sup>L</sup> |
| Q3 <sup>L</sup> | Q6 <sup>M</sup> |
| Q4 <sup>S</sup> | Q6 <sup>L</sup> |
| Q4 <sup>M</sup> | Q7 <sup>M</sup> |
| Q4 <sup>L</sup> | Q8 <sup>M</sup> |
| Q5 <sup>S</sup> |                 |







# SOLID, LOYAL TRIMA

The new Trima Q-series shows how clever engineering makes all the difference. With outstanding visibility, improved work angles and super easy implement change. You just won't find a more high-functioning, usable front loader.

Our Trima loaders are designed to deliver the best possible productivity and user benefits over a long period of time. Numerous unique features combine to give the Q-series loaders their renowned reliability and service life. Heavy-duty details together with robust design and quality focus are basic, obvious examples of such attention to detail. Our many years of experience and constant dialogue with farmers also play an important role. We are well-versed in user

requirements. We know which situations cause the greatest wear, tear and stresses on the loader. It is the given starting point in our continuous development work, and is the explanation as to why Trima is certainly one of the most durable front loaders in existence – you can rely on that!

## 1. IMPROVED LOCKING ON PIVOT PINS

All pins are galvanised and equipped with Trima unique pin lock. The tool carrier has extra strong pins where stresses are particularly great. A hinged locking plate with a compact rubber ring prevents axial play, keeps the lubrication grease in place and fixes the pin on both sides.

## 2. ROCK-STEADY SUPPORT LEGS

Fully integrated heavy-duty design with flexible positions makes it quick and easy to connect and disconnect your Trima loader. No tools are required and there are no loose parts.

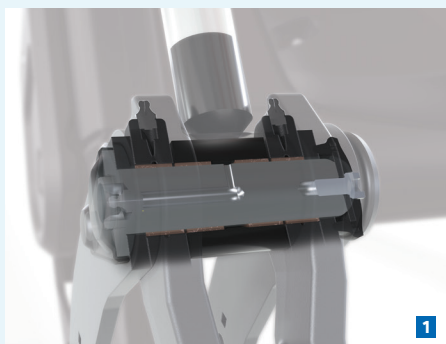

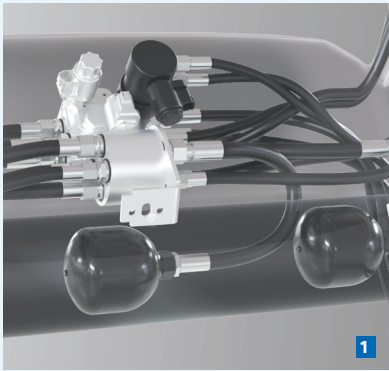

1



2

**1. EXACT CONTROL WITH CENTRAL VALVE**

Our central distribution valve has many advantages. It gives the loader exact control and optimal force for heavy-duty tasks. The location of the valve gives optimal vision for the driver and offers outstanding durability, as all the components are being protected by a high impact resistant cover.

**2. HI-VISIBILITY TOOL CARRIERS**

The tool carriers for the new Q-series comes in a high visibility optimized design. With less obstructive material, you will have a clear view of your implements back. Nonetheless, torsional strength and durability is stronger than ever.



3

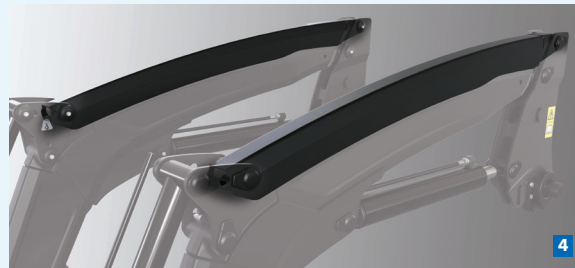

4

**3. COMPACT IMPLEMENT LEVEL INDICATOR**

The level indicator has a protected position at the inside of the loader. It is easy to see, easy to set and can be adjusted in three positions for various implements, ensuring exact precision of the implement's angle with the ground.

**4. Q LINK - PRECISE SELF LEVELLING**

Q Link gives you effective self levelling. The implement keeps its pre-selected angle, from the ground up to maximum height. The design is curved and chamfered which improves visibility for excellent handling of straw bales or pallets.



5



6

**5. Q LOCK - HYDRAULIC IMPLEMENT LOCKING**

Our improved hydraulic implement locking ensures simple and comfortable changes of implements. Using the built-in on/off function you can change implements without getting out of your drivers seat.

**6. SAVE TIME WITH SELECTO FIX**

Gain time and avoid trouble. With a simple movement, you can easily attach the implement hydraulics without any problems, even under pressure.

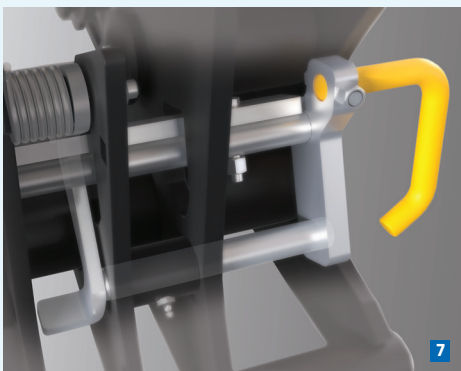

7

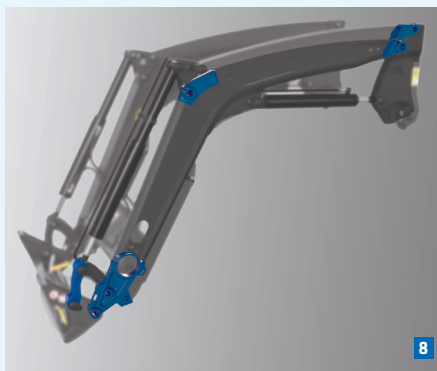

8

**7. ALWAYS RIGHT WITH CLIC-ON™**

Our clever, semi-automatic implement lock ensures that implements only can be attached one way - the right way. Maximises simplicity and minimises downtime. Also notice the rigid design.

**8. CASTED AND FORGED PARTS**

The Q-series has forged rear arm parts and casted knee, front part and front link. Giving it superior strength and durability. It enables you lift heavy loads often - and save time.

**9. STRONG AND SMART WITH TWIN "U-BEAMS"**

The twin "U-beams" of the Trima loader arms gives the loader unrivalled strength. The 80mm wide arm profile also features embossed sides to improve stiffness and give it a modern appearance.

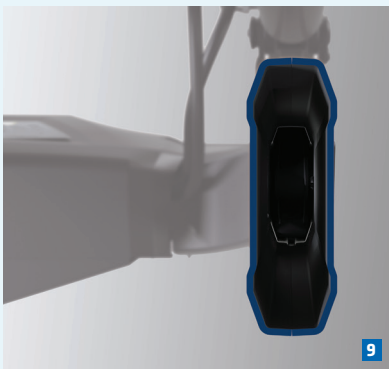

9

**Trima Q-series**

A front loader range that builds on the traditional Trima values of a long life span, high productivity and first class ergonomics.





## SUPERIOR VIEWS WITH Q VISION

Trima's unique loader design allows you to work with the best possible visibility. We call it Q Vision.

No pipes or hoses that restrict your view. No dirt or rubbish that can accumulate, even if you fit options to your loader. These are the obvious advantages of Q Vision, where all pipes and hoses are protected in the loader arm. Even if you install extra options onto the loader, you get the same smooth lines.

### Hi-visibility tool carriers

The tool carriers for the new Q-series comes in a high visibility optimized design. With less obstructive material, you will have a clear view of your implement's back. Nonetheless, torsional strength and durability is stronger than ever.

As always with Trima's premium products, the locking of the implement is semi-automatic, we call it Clic-on™. The tool carriers also has two levers for unlocking the implement. One centred and one side mounted, yet well protected into the tool carrier design. The side mounted locking device also doubles as an implement lock indicator, giving you full visibility, so that you can easily see that the implement is in locked position.

## DRIVE SMOOTHER WITH SOFTDRIVE

Our innovative dampening system SoftDrive reduces the strain on the loader and subframes, as well as on the driver and tractor. You don't see it, but we guarantee you will feel it.

### How it works

SoftDrive protects everything between the load in the implement and the ground. With its clever location, protected inside the cross tube, SoftDrive reduces the stress on the loader and attachment. That means no damage on hoses, pipes or accumulators. But it also makes driving smoother for the driver. SoftDrive for Q-series has been engineered to cope



with high flows in the oil system to allow outstanding dampening.

- Protected in the cross tube, no damage on hoses, pipes or accumulators.
- Easy connection to the Q Central Valve.
- Electrical on/off switch.





# FINDING THE RIGHT ANGLE

Q Level gives you optimal work angles when working with buckets and loose material. In practical terms, Q Level enables you to crowd up the bucket to a crowd angle of 58° at a transport height of around 65-85cm. The result is a significantly less spillage over bucket tip or back.

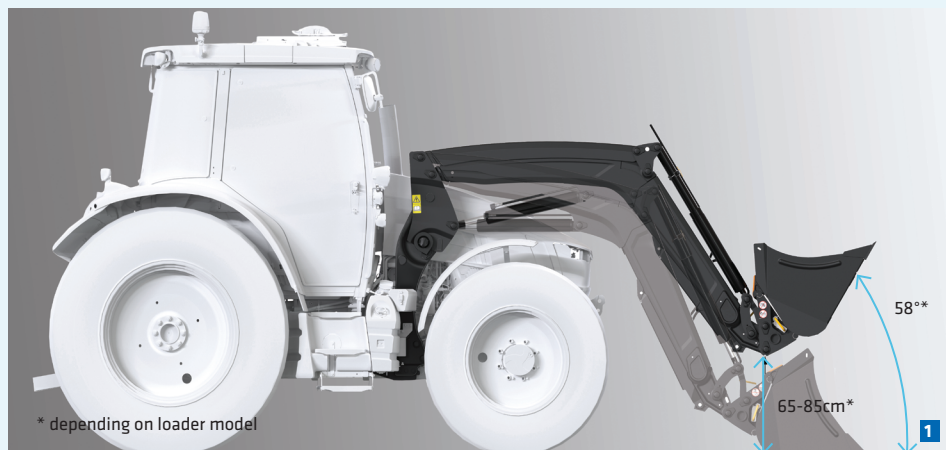

### 1. LARGER CROWD ANGLE EVEN AT LOW LIFTING HEIGHTS.

Trima Q-series enables a crowd angle of 58° at a lifting height of 65-85 cm depending on loader model. At operational height this reduces spillage to a minimum.

### 2. STRONG LOCKING ON PIVOT PINS

All pins are galvanised and fitted with Trima's unique pin lock. The tool carrier has extra strong pins where stresses are particularly great. The pivot stop plate and the compact rubber disc prevents axial play, keeps the lubrication grease in place and fixes the pin on both sides.

### 3. PROVEN AND DURABLE SUBFRAME

Trima's Delta subframe has extraordinarily heavy-duty dimensions with precision machined contact surfaces. Details such as the 60 mm wide U-support and 40 mm locking pin enables the loader to cope with difficult and heavy jobs for many years.

### 4. FULL LOAD WITH LARGE WORK ANGLES

This is a strong contributor to Trima documented high levels of usability and productivity. Of course, the design coordinates with the performance of the original implement, which further optimises your use and capacity of the equipment.

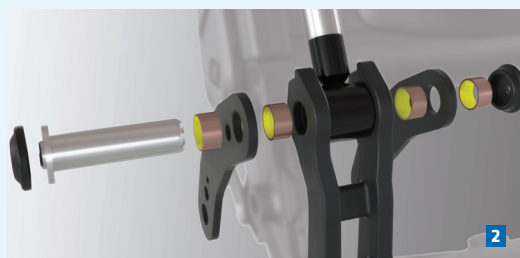





# FRONT LOADERS WITH PARALLEL LINKAGE

LOADER MODEL		Q3 <sup>3</sup>	Q3 <sup>M</sup>	Q3 <sup>4</sup>	Q4 <sup>5</sup>	Q4 <sup>M</sup>
<b>TRACTOR DATA</b>						
Tractor PTO HP Range	hk	60-100	60-100	60-100	80-140	80-140
Tractor weight (max)	kg	4 000	4 000	4 000	5 000	5 000
Specified Pressure	bar	195	195	195	195	195
Specified Flow	l/m	50	50	50	60	60
<b>LOADER PHYSICAL DATA</b>						
Arm width (C-C)	mm	1040	1040	1040	1040	1040
Weight - Front loader	kg	520	520	525	575	575
<b>LIFT HEIGHTS AND BUCKET ANGELS</b>						
Maximum Lift Height - Measured at Pivot Pin	m	3,55	3,55	3,81	3,79	3,79
Maximum Lift Height - Under Level Bucket	m	3,25	3,25	3,51	3,49	3,49
Maximum Dump Angle at Maximum height	° (Degrees)	58	58	53	58	58
Maximum Rollback Angle at ground	° (Degrees)	48	48	50	48	48
<b>LOADER FORCES</b>						
Lift Capacity to Maximum Height At Pivot Pin	kg	1550	1850	1740	1920	2 260
Lift Capacity, 1,5m (59 in) Height -800mm (31.5 in) From Pivot Pin	kg	1570	1870	1760	1940	2 280
Breakout Force - At Pivot Pin	kg	1630	1960	1830	1990	2 320
Rollback Force at Ground Level -800mm (31.5 in) From Pivot Pin	kg	2 390	2 870	3 430	3 360	3 360
<b>REACH DATA</b>						
Clearance with bucket dumped 45 deg	mm	2 580	2 580	2 840	2 820	2 820
<b>LOADER POSITION</b>						
Digging Depth	mm	160	160	160	160	160





	Q4 <sup>L</sup>	Q5 <sup>S</sup>	Q5 <sup>M</sup>	Q5 <sup>L</sup>	Q6 <sup>M</sup>	Q6 <sup>L</sup>	Q7 <sup>M</sup>	Q8 <sup>M</sup>
	80-140 5 000 195 60	100-180 6 000 195 80	100-180 6 000 195 80	100-180 6 000 195 80	120-220 7 000 195 90	120-220 7 000 195 90	140-280 8 000 195 100	>160 9 000 195 100
	1040 580	1040 620	1040 620	1040 625	1040/1200 720	1040/1200 750	1040/1200 760	1200/1420 830
	4.02 3.72 54 49	4.06 3.76 57 48	4.06 3.76 57 48	4.20 3.90 54 49	4.25 3.95 57 48	4.55 4.25 53 52	4.60 4.30 54 49	4.96 4.66 53 47
	1780 1820 1910 3400	1980 2100 2290 3370	2300 2440 2640 3910	1930 2020 2160 3420	2470 2700 2840 4540	1980 2110 2230 4000	2490 2810 2990 4600	2590 2810 3630 4510
	3050	3090	3090	3230	3280	3580	3630	3990
	180	160	160	170	160	200	160	170





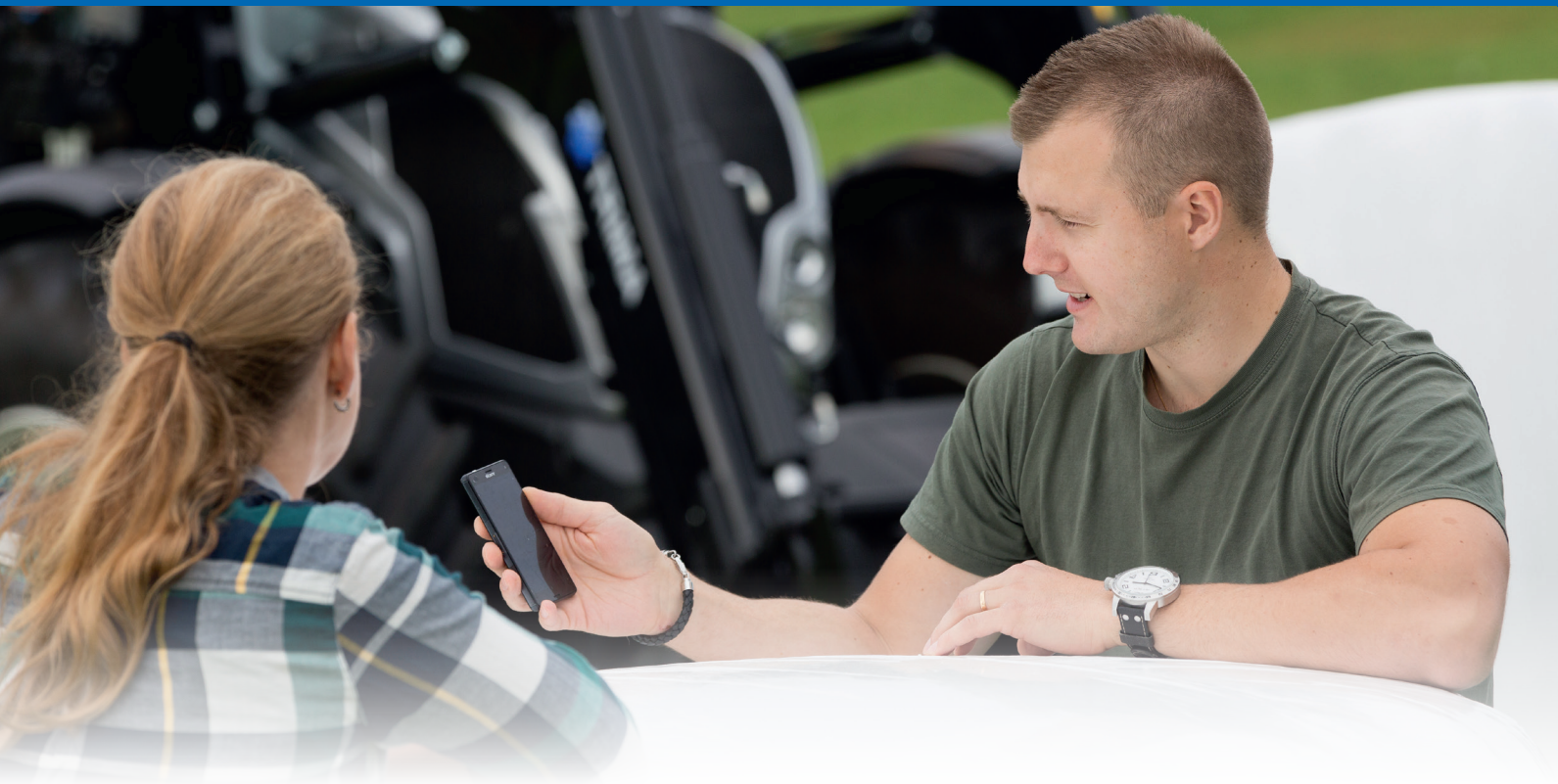

## THE SUPPORT

As a Trima owner, you'll not only have a world-leading front loader, but also world-leading level of reliability and service. Your purchase does not end our commitment to you – it's only the beginning.

Your Trima has to perform at its best for a long time. We have built up a strong global organisation with a comprehensive service network, giving you easy and fast access to locations for service, spare parts and knowledgeable support - wherever you operate in the world. You can be sure that our service and support meets the same standard as our products – always aiming for 100 percent customer satisfaction. To us, second best is not enough.

**Absolute customer focus.** In order to support you as a customer, we have created routines that ensure all the departments in our organisation are focused on your requirements.

**Quick online help.** You'll have round-the-clock online access to spare part details, instructions and other important information.

**Tight-knit spare part network.** Spare parts are available from our subsidiaries as well as from larger Trima representatives the world over.

**Proximity.** Our world-leading distribution network guarantees proximity to you, no matter where you are.

Global technical support. As a Trima customer, you always have access to prompt technical support. All over the world, our representatives can provide knowledgeable and high-quality service.



**Constant follow-up.** Your viewpoints and suggestions for improvement are gathered together and centrally processed. This follow-up functions as a valuable basis for us when developing new loaders, implements and subframes. The development of Trima is the result of close cooperation with users all over the world.

Find your local dealer at [trima.nu](http://trima.nu)



# ”We take great pride in forward-thinking”

Since 1949, we have invented and refined the art of making front loaders. Today, we have top-of-the-line production facilities all over the world. We test-run every detail on our products meticulously, to meet the demands of modern farming and build the best loaders possible. Meet our Product Manager for loaders, Urban Rönqvist.

– Continuous development, decade after decade. That is the core of our long and successful history. And it also points to our future, says Urban Rönqvist, who has overseen the long, meticulous work from the developers at Ålö, leading up to the new Trima Q-series.

The history behind Ålö starts with the idea of company founder Karl-Ragnar Åström. In the mid-1940s, he inherited the family farm in Brännland, just outside Umeå in Sweden. At this time all loading and unloading was done manually. In 1947, Karl-Ragnar designed the first Swedish front loader for his own use.

– Karl-Ragnar’s spirit of invention still lives on at Ålö. It’s part of our DNA. Being at the forefront of design and development means that we are constantly looking for improvements, both large and small. We take great pride in forward-thinking, says Urban Rönqvist.

Today we are market leaders in more than 15 countries and the undisputed world leader in front loaders and associated implements, with state of the art production facilities in Sweden, USA, France and China.

Karl-Ragnar Åström, being a farmer himself, had one single goal in mind when he created the first Ålö loader in the 1940s: To facilitate and rationalise the farmer’s work. That goal still applies today.

– When you supplement your tractor with a Trima you should know that you are acquainting yourself with a loader range that is designed with total regard for your needs, a range that has been tried and tested for many years, says Urban Rönqvist.







**Ålö AB**

Brännland 300, SE-901 37 Umeå

Tel. 090-17 04 90

[www.alo.se](http://www.alo.se)

**CLIMATE  
COMPENSATED  
PAPER**



Some front loaders in this brochure are fitted with extra equipment. Certain products may be optional extra equipment. Some of the products are not available on all markets. Product specifications and performance data stated can vary depending on the tractor model. Working with front loaders and accompanying implements is not without risk. Serious injuries to people and damage to materials can occur in the event of incorrectly carried out work. Show consideration to your surroundings, use common sense and comply with local laws and regulations. Always read carefully through the instruction manual supplied. Only use original spare parts and accessories. Ålö's product range is continually being developed. We reserve the right at any time to alter specifications, prices and versions with no obligation on our part. ©,™ Trademarks of Ålö AB.